

# AKAI

## Operator's manual

CAR AUDIO - MP3 / CD RECEIVER

# ACAC100UC



Operator's manual (GB) 1-11

Gebruiksaanwijzing (NL) 13-24

Manuel de l'utilisateur (FR) 26-37

## TABLE OF CONTENTS

1. LOCATIONS OF CONTROLS .....	1
2. INSTALLATION .....	2
3. TO SUPPORT THE UNIT .....	2
4. DETACHING THE FRONT PANEL .....	3
5. ATTACHING THE FRONT PANEL .....	3
6. ISO CONNECTOR .....	4
7. OPERATING INSTRUCTIONS .....	5
8. USING THE RDS FUNCTION .....	7
9. CD CONTROL LOCATION OF PARTS .....	9
10. HOW TO SELECT MP3 FILES .....	10
11. TECHNICAL INFORMATION .....	11

## LOCATIONS OF CONTROLS

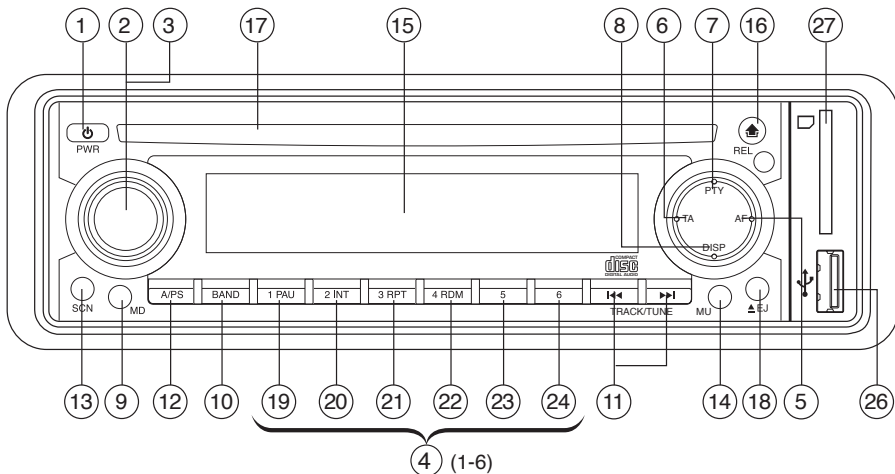

1. POWER ON / OFF ( ⏻ )
2. FUNCTION SELECT BUTTON: BASS / TREBLE / BALANCE / FADER / TA SEEK / MASK  
DPI / RETUNE / AUDIO DSP / LOUDNESS / ESP / CD MULTI / BEEP / SEEK / STEREO  
/ LOCAL (SEL)
3. VOL UP / VOL DOWN FOR BASS / TREBLE / BALANCE / FADER
4. PRESET STATIONS (1,2,3,4,5,6)
5. 'AF' function (ALTERNATIVE FREQUENCIES)
6. 'TA' function (TRAFFIC ANNOUNCEMENT)
7. 'PTY' function (PROGRAM TYPE)
8. DISPLAY BUTTON (DISP)
9. MODE BUTTON (MD)
10. BAND BUTTON (BAND)
11. AUTOMATIC OR MANUAL TUNING (FREQ UP ►► OR FREQ DOWN ◀◀ /  
CD TRACK / SEARCH BUTTON
12. AUTO SEEK SEARCH TUNING (A/PS)
13. 'SCAN' AUTOMATIC TUNING CONTROL (SCN)
14. MUTE BUTTON (MU)
15. LCD DISPLAY
16. PANEL RELEASE BUTTON ( 📏 )
17. CD SLOT
18. CD EJECT BUTTON ( 📏 )
19. PAUSE BUTTON
20. INTRO BUTTON (Preview all Tracks)
21. REPEAT BUTTON
22. RANDOM BUTTON
- 23, 24. + 10 TRACK SEARCH UP / DOWN
25. RESET BUTTON (Behind Front Panel)
26. USB PORT
27. MULTI-MEDIA CARD (MMC)/SD CARD SLOT

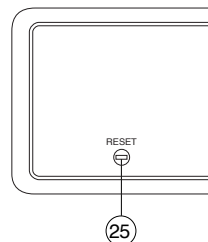

## INSTALLATION

### PRECAUTIONS

- Choose the mounting location carefully so that the unit will not interfere with the normal driving functions of the driver.
- Avoid installing the unit where it would be subject to high temperatures, such as from direct sunlight or hot air from the heater, or where it would be subject to dust, dirt or excessive vibration.
- Use only the supplied mounting hardware for a safe and secure installation.
- Be sure to remove the front panel before installing the unit.

### Mounting angle adjustment

Adjust the mounting angle to less than 20°.

### MOUNTING EXAMPLE

#### Installation in the dashboard

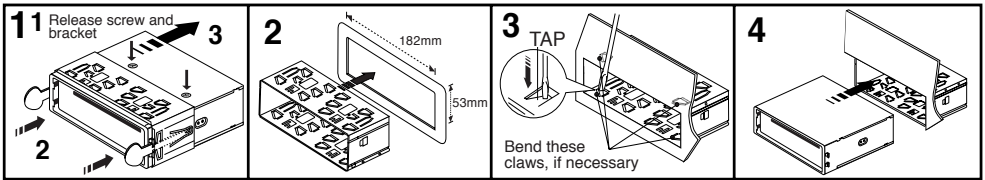

**Note:** Keep the release key in a safe place as you may need it in the future to remove the unit from the car.

### TO SUPPORT THE UNIT

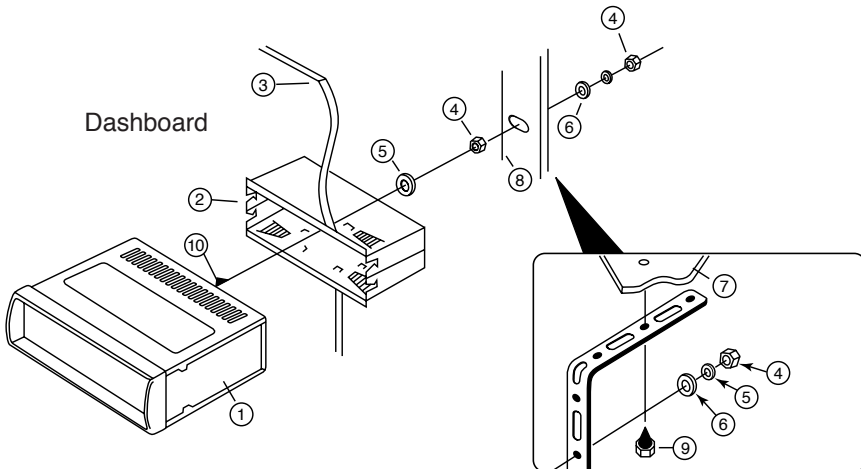

1. UNIT
2. RELEASE CASE
3. DASH BOARD
4. HEX NUT
5. LOCK WASHER
6. PLAIN WASHER
7. CAR BODY
8. REAR SUPPORT STRAP
9. TAPPING SCREW
10. M5 X 15 HEX BOLT

## Detaching and attaching the front panel

The front panel of this unit can be detached in order to prevent the unit from being stolen.

### DETACHING THE FRONT PANEL

Before detaching the front panel, be sure to press the PWR button OFF first.

Pull out the panel towards you in order to detach completely the panel from the main unit.

Refer to instruction.

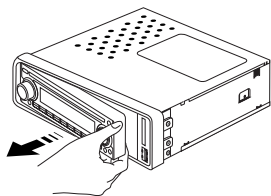

### ATTACHING THE FRONT PANEL

Make sure the front panel is the right way up when attaching it to the unit as it cannot be attached upside down. Bring side B of panel to side A of main unit.

Insert the panel in and push until it clicks.

Panel is attached.

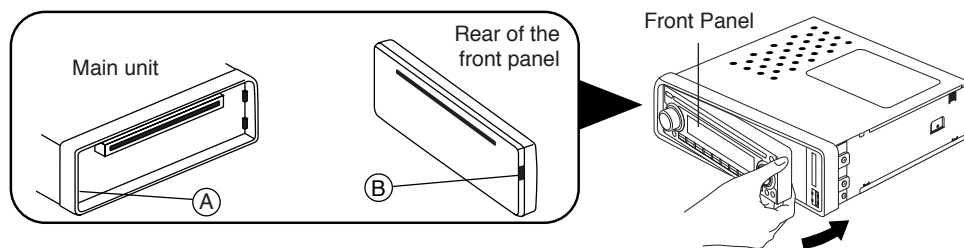

### Notes:

- Do not press the front panel hard against the unit when attaching it. It can be easily attached by pressing it lightly against the unit.
- When you carry the front panel with you, put it in the supplied front panel case.
- Do not press hard or give excessive pressure to the display window of the front panel when attaching it to the unit.

## ISO CONNECTOR

RCA Jack Line Out

White (left) Red (right)

RCA Jack Line In

White (left) Red (right)

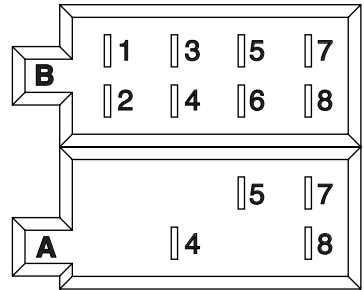

### CONNECTOR A

4. MEMORY +12V

5. AUTO ANTENNA OUTPUT

7. +12V (TO IGNITION KEY)

8. GROUND

**Note:** (connector A no. 7) must be connected by car ignition key in order to avoid that car battery being drained when the car will be not used for long period.

### CONNECTOR B

1. REAR RIGHT SPEAKER (+)

2. REAR RIGHT SPEAKER (-)

3. FRONT RIGHT SPEAKER (+)

4. FRONT RIGHT SPEAKER (-)

5. FRONT LEFT SPEAKER (+)

6. FRONT LEFT SPEAKER (-)

7. REAR LEFT SPEAKER (+)

8. REAR LEFT SPEAKER (-)

## Maintenance

### FUSE REPLACEMENT

If the fuse blows, check the power connection and replace the fuse. If the fuse blows again after the replacement, there may be an internal malfunction. In this case, consult your nearest repairing center.

### Warning

Use the specified amperage fuse for each lead. Use of a higher amperage fuse may cause serious damage.

# OPERATING INSTRUCTIONS

## 1. POWER ON/OFF

By pressing this key, the unit is switched on or off.  
This unit is turned on by pressing any key.

## 2. SELECT

## 3. VOLUME UP/DOWN

Turning the VOL knob Right or Left (3), you can adjust VOL/BASS/TREB/BAL/FAD. To select other functions, press the SEL (2) button shortly until the desired functions is shown on the display. Figure 1 shows how control functions are selected using the SEL button.

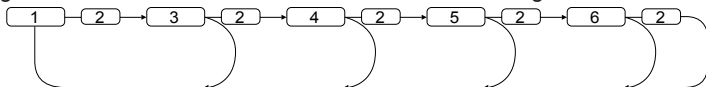

Fig. 1 Selection of sound control functions

1. VOL    2. SEL    3. BAS    4. TRE    5. BAL    6. FAD

Turning the VOL knob Right or Left. Increase or decrease the volume by turning or . These buttons can be used to adjust the BASS, TREBLE, BALANCE and FADER.

**Note:** When you press and hold "SEL" key longer than 2 sec, unit enters FUNCTION select mode. In order to exit such mode, simply press "DISP" key or just wait around for 8 sec. and unit automatically exits.

## TA SEEK/TA ALARM (2)

When press the SEL button for more than 2 seconds, it is activated as selecting mode of these function.

TA SEEK Mode or TA ALARM mode is selected by or .



### - TA SEEK mode:

When newly turned station does not receive TP information for 5 sec., the radio retunes to next station which has not the same station (PI) as the last station, but has the TP information.

In TA seek mode, the current station can be changed to the completely different station because the unit searches TP station when the field strength of the current station is very weak, or the current station has no TP signal.

### - TA ALARM mode:

Any automatic retune mode is not activated, just can hear Beep sound.

## MASK DPI (2)

When press the SEL button for more than 2 seconds, it is activated as selecting mode of these function.



MASK DPI: masked only the AF which has different PI.

MASK ALL: masked the AF which has different PI and NO RDS signal with field strength.

## RETUNE L / S CONTROLS (2)

When press the SEL button for more than 2 seconds, it is activated as selecting Retune mode.

**RETUNE L:** Select 90 seconds as the initial time of automatic TA search.

**RETUNE S:** Select 30 seconds as initial time.



## AUDIO DSP CONTROLS (2)

When press the SEL button for more than 2 seconds, it is activated as selecting mode of these function.

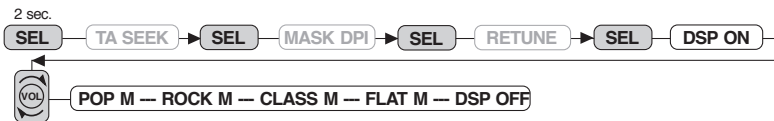

### LOUDNESS CONTROLS (2)

When press the SEL button for more than 2 seconds, it is activated as selecting mode of these function.



LOUD ON/OFF mode is selected by or knob. The bass and treble response will be boosted.

### ESP MODE (2)

When press the SEL button for more than 2 seconds, it is activated as 10 sec. or 40 sec. of ESP mode can be selected.

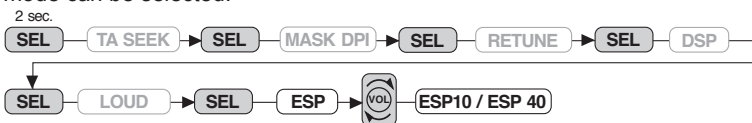

### MULTI CD SECTION MODE (2)

When press the SEL button for more than 2 seconds, it is activated as selecting mode of these function.

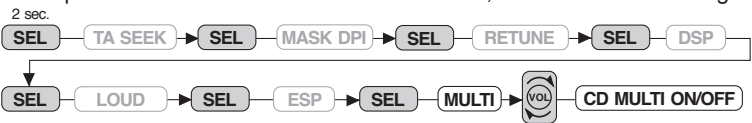

CD MULTI ON/OFF mode is selected by or knob. CD MULTI ON: Read multi session CD. CD MULTI OFF: Read first section only.

### BEEP MODE (2)

When press the SEL button for more than 2 seconds, it is activated as selecting mode of these function.

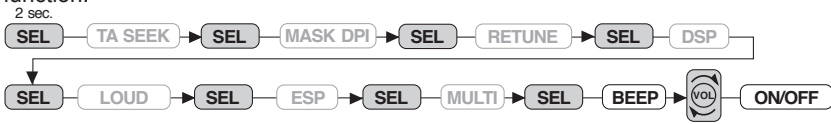

BEEP ON: BEEP sound can be heard from speaker when the buttons are pressed.

### SEEK MODE (2)

When press the SEL button for more than 2 seconds, it is activated as selecting mode of these function.

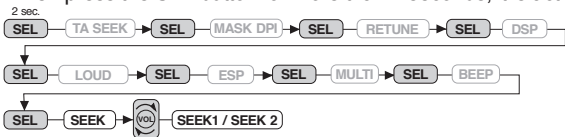

**SEEK 1:** When SEEK 1 mode is activated, AUTO SEEK SCAN is stopped when station is detected even user still push SEEK button.

**SEEK 2:** Auto SEEK SCAN is not stopped even station is detected if user push SEEK button. When release this SEEK button, then stop when station is detected.

## STEREO/MONO (2)

When press the SEL button for more than 2 seconds, it is activated as selecting mode of these function.

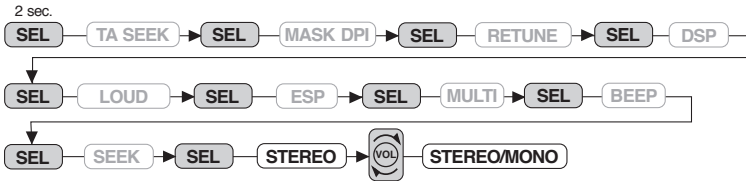

When FM stations are weak and are disturbed, listening can be improved by selecting MONO.

## LOCAL/DX (2)

When press the SEL button for more than 2 seconds, it is activated as selecting mode of these function.

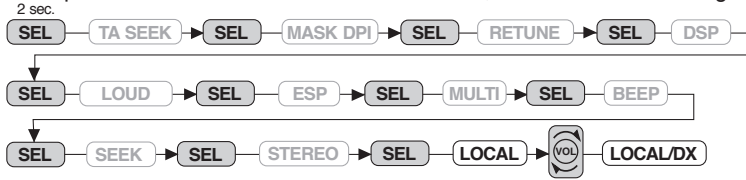

“Local” position in areas with strong signals to let radio stop at only strong stations during manual tuning (LOC appears). Press to Distant position in areas with weak signals to listen to all stations.

## 4. PRESET STATIONS (1,2,3,4,5,6)

### (A) RADIO MODE:

When pressed short, these keys select a preset station directly. When pressed longer than 1 sec., current station is stored in preset memory bank. When PTY mode is selected, the PTY switch is shared as follows:

PTY music group ---- PTY speech group ---- OFF

#### MUSIC

1. POP M, ROCK M
2. EASY M, LIGHT M
3. CLASSICS, OTHER M
4. JAZZ, COUNTRY
5. NATION M, OLDIES
6. FOLK M

#### SPEECH

1. NEWS, AFFAIRS, INFO
2. SPORT, EDUCATE, DRAMA
3. CULTURE, SCIENCE, VARIED
4. WEATHER, FINANCE, CHILDREN
5. SOCIAL, RELIGION, PHONE IN
6. TRAVEL, LEISURE, DOCUMENT

### (B) CD/MP3 PLAYER MODE:

1. PAUSE
2. INT
3. RPT
4. RDM

## USING THE RDS FUNCTION

### What is RDS?

The RDS (Radio Data System) is a digital information system developed by the EBU (European Broadcast Union). Piggy-backed on normal FM broadcasts, RDS offers a variety of information services and automatic retuning functions for RDS-compatible car stereos.

## 5. 'AF/REG' function (ALTERNATIVE FREQUENCIES)

When pressed short, AF/REG switching mode is selected.

When AF/REG switching mode is selected, the radio checks the signal strength of the AF all the time. When pressed long, it is activated as regional mode ON/OFF.

### – Regional mode ON:

AF switching or PI SEEK is implemented to the station which have all PI codes same as current station. REG segment is turned on, in LCD display.

### – Regional mode OFF

The regional code in the format of PI code is ignored when AF switching or PI SEEK is implemented.

## 6. 'TA' function (TRAFFIC ANNOUNCEMENT)

When pressed short, it is activated as TA mode on or off

When TA mode is on and traffic announcement is transmitted

– When the unit is in CD/MP3 mode, it will switch to radiomode temporarily.

– If the volume level was under the threshold point, it will be raised to the threshold point.

– When TP station is received, TP segment is turned on in LCD display.

## 7. 'PTY' function (PROGRAM TYPE)

PTY MUSIC ---- PTY SPEECH ---- PTY OFF

While selecting PTY type, its selection is implemented by preset buttons as described in preset key. When PTY is selected, the radio starts to search corresponding PTY information, and stops if the corresponding PTY information is detected.

## 8. DISPLAY (DISP)

When this key is pressed, it is operated as the conversion of each display mode as follow.

**1) In case of receiving RDS station.**

**RADIO MODE**

PS ---- CT ---- FREQ ---- PTY

**CD/MP3 PLAYER MODE**

CDP ---- CT ---- PS ---- FREQ ---- PTY

**2) In case of receiving NON RDS station**

**RADIO MODE**

FREQ ---- CLOCK ---- NO PTY

**CD/MP3 PLAYER MODE**

CDP ---- FREQ ---- CLOCK ---- NO PTY

Each display time is several seconds, and come back to 1'st position after several seconds.

Notes: • **CT** = clock time • **FREQ** = frequency • **CDP** = CD player

## 9. MODE BUTTON (MD)

By pressing this key, user can select. AUX/TUNER/CD-MP3/USB or MMC/SD mode.

Note: Selection of USB or MMC/SD mode only works if a USB or Card is placed in the slot.

## 10. BAND BUTTON (BAND)

Each band is toggled cyclically by pressing this key FM1---FM2---FM3.

## 11. AUTOMATIC OR MANUAL TUNING (FREQ UP ►► OR FREQ DOWN ◀◀ )

**(A) RADIO MODE**

When pressed short, these keys are operated as MANUAL tuning mode.

When pressed longer than 1 sec., they are operated as SEEK tuning mode.

**(B) CD/MP3 PLAYER MODE**

When pressed short, they are operated as TRACK UP or TRACK DOWN mode.

When pressed longer than 1 sec., they are operated as CUE or REVIEW mode.

## 12. AUTO SEEK SEARCH TUNING (A/PS)

By pressing shortly, the radio searches for each preset station.

When field strength level is bigger than the threshold level of stop level, the radio is holding at that preset number for 5 sec. with releasing mute, and then searches again.

By pressing longer than 1 sec., and then 6 strongest stations are preset to the corresponding preset number.

When AS operation is finished, the radio executes the preset scan.

## 13. 'SCAN' AUTOMATIC TUNING CONTROL (SCN)

This key is operated as RADIO SCAN. The operation is similar as normal search but different thing is holding 5 seconds on every station detected in RADIO SCAN mode.

## 14. MUTE BUTTON (MU)

Press this button, audio will disappear. Press this button again in order to hear audio newly.



## 15. LCD DISPLAY

The Liquid Crystal Display will display the current state of the unit.



## **CD CONTROL LOCATION OF PARTS**

### **TRACK/SEARCH BUTTON (11)**

#### **FORWARD AND REVERSE TRACK SEARCH (or changing songs)**

Press the SKIP button (  or  ) during play to go to the desired track(song).

 .....REVERSE       .....FORWARD

Press and hold the SKIP button (  or  ) during play to scan the disc at high speed. When the desired music section of the disc is found, release the button. Normal play will resume.

## **17. CD SLOT**

### **18. CD EJECT BUTTON**

Press the EJECT button to remove the CD.

### **19. PAUSE BUTTON**

During "PLAY", press (19) 'PAU' button to "PAUSE". Press it again to resume play.

### **20. INTRO BUTTON (Preview all Tracks)**

When this button is pressed, 'INT ON' indication is displayed and the first several seconds of each track of the disc are played. Press again to stop intro and listen to track.

### **21. REPEAT BUTTON**

When this button is pressed, 'RPT ON' indication is displayed and play of the selected track will be continually repeated until the Track repeat mode is cancelled by pressing 'RPT' button again.

### **22. RANDOM BUTTON**





When this button is pressed, 'RDM ON' indication is displayed and each track of the disc are played in random instead of normal progression. To cancel RANDOM mode, press 'RDM' button (22) again.

### **23, 24. 10 TRACK UP/DOWN SELECT: (In case of MP3 files)**





**M5: 10 Track down / M6: 10 Track up**

## **HOW TO SELECT MP3 FILES**





### **1. Searching Track:**

- Press “A/PS”, then searching track is activated.
- Press “SEL”, then the first digit is blinking.
- With “VOL  / VOL  ” knob, select first digit you want.
- Press “SEL”, then the first digit is fixed and second digit is blinking.
- With “VOL  / VOL  ” knob, select 2'nd 3'rd respectively.
- Then automatically the song you selected will start.

### **2. Searching File Name:**

- Press “A/PS” twice, then file search is activated.
- Press “SEL”, then the first directory is displayed.
- With “VOL  / VOL  ” knob, you can select the directory you want.
- Press “SEL” again, then the directory is fixed and the first file name is displayed.
- With “VOL  / VOL  ” knob, you can select the file you want.
- Press “SEL”, then the song you selected will start.

### **3. Searching Character:**

- Press “A/PS” 3 times, then character search mode is activated.
- Press enter “SEL” button, then “A” character is displayed.
- With “VOL  / VOL  ” knob, you can select the letter you want.
- Press “SEL” key longer than 2 sec.
- The song which has same character you selected is displayed.
- With “VOL  / VOL  ” knob, you can select the song you want.
- Press “SEL” key, then the song you selected will start.

### **• RESET**

Reset button (25) is placed on the housing.

The reset button is to be activated for the following reason:

- Initial installation of the unit when all wiring is completed.
- All the function button do not operate.
- Error symbol on the display.

## **Connecting it to Portable MP3 Player**

### **26. USB Port**

Using USB cable to connect Your Portable MP3 Player.

### **27. MULTI-MEDIA CARD (MMC) / SD CARD SLOT**

Support MP3 ID3 format music only.

### **\* IMPORTANT INFORMATION:**

*BECAUSE OF THE GREAT VARIETY OF PRODUCTS WITH USB,SD AND MMC CARD PORTS AND THEIR SOMETIMES QUITE MANUFACTURER-SPECIFIC FUNCTIONS WE CAN NEITHER GUARANTEE THAT ALL DEVICES WILL BE RECOGNIZED NOR THAT ALL OPERATING OPTIONS THAT ARE POSSIBLE IN THEORY WILL ACTUALLY WORK*

## TECHNICAL INFORMATION

### CD/MP3 PLAYER SECTION

Signal to noise ratio	> 60 dB
Channel separation	> 50 dB (1kHz)
Frequency response	20Hz - 20 kHz

### TUNER (FM)

Frequency range	87.5 -108 MHz
Sensitivity	2.8 $\mu$ V
Stereo separation	30 dB
Signal to noise ratio	50 dB
Channel step	50 kHz
Intermediate frequency	10.7 MHz

### LINE-OUT

Output	350 mV
Impedance	10k Ohm

### GENERAL

Power supply	12V DC (10.8-15.6V allowable)
Power consumption	10A
Standby power consumption	under 10 mA
Speaker impedance	4 or 8 Ohm
Output power	40W x 4CH

**Note:** Specifications and the design are subject to possible modification without notice due to improvement.



#### Disposal of Used Electrical & Electronic Equipment

The meaning of the symbol on the product, its accessory or packaging indicates that this product shall not be treated as household waste. Please, dispose of this equipment at your applicable collection point for the recycling of electrical & electronic equipments waste. In the European Union and Other European countries which there are separate collection systems for used electrical and electronic product. By ensuring the correct disposal of this product, you will help prevent potentially hazardous to the environment and to human health, which could otherwise be caused by unsuitable waste handling of this product. The recycling of materials will help conserve natural resources. Please do not therefore dispose of your old electrical and electronic equipment with your household waste. For more detailed information about recycling of this product, please contact your local city office, your household waste disposal service or the shop where you purchased the product.